



ARGON 18



2018



ARGON 18

Radsport: Eine umfassende Leidenschaft

Bei Argon 18 sind wir erfüllt von der Leidenschaft zum Velo. Es ist fundamental: Die Liebe zum Fahrrad in seiner ganzen Schönheit bedeutet tiefe Verpflichtung zur Tradition und Moderne.

Auf der einen Seite verspüren wir ständig den Impuls, weiter und höher zu gehen, kreativ zu sein und die etablierten Grenzen der Qualität und Technologie zu überwinden, auf der anderen Seite sind wir fest mit den Grundwerten des Radsports in seiner Gesamtheit verbunden, seiner Philosophie und Tradition.

Für uns ist das Fahrradfahren mehr als ein simpler Sport: Es ist eine Kunst für sich.

Preis- und Spezifikationsänderungen ohne Voranmeldung vorbehalten.
Alle Preisangaben in Schweizer Franken (CHF).

Le cyclisme : une passion tous azimuts

Chez Argon 18, nous sommes habités par la passion du vélo. C'est fondamental : notre amour du vélo, dans toute sa beauté, est ancré dans la tradition comme dans la modernité.

Nous avons pour objectif d'aller toujours plus loin et plus haut, d'innover et de repousser les frontières de l'excellence et de la technologie. Mais nous sommes également fortement attachés aux valeurs fondatrices du cyclisme dans son ensemble, à sa philosophie et à ses acquis.

Pour nous, le cyclisme est plus qu'un simple sport : c'est un art en soi.

Prix et spécifications sous réserve de modifications sans préavis.
Tous les prix s'entendent en francs suisses (CHF).

Bikes 2018

ROAD



GALLIUM PRO
ab / à partir de **5195.-**



GALLIUM
ab / à partir de **3595.-**



NITROGEN PRO
ab / à partir de **5695.-**



NITROGEN
ab / à partir de **3795.-**



KRYPTON
ab / à partir de **2495.-**



GO!
ab / à partir de **2195.-**



GALLIUM PRO DISC
ab / à partir de **5095.-**



KRYPTON XROAD
ab / à partir de **2995.-**

TRIATHLON



E-119 TRI+
ab / à partir de **6995.-**



E-119 TRI
ab / à partir de **6395.-**



E-117 TRI
ab / à partir de **3395.-**

Optimale Balance

Ein perfekt ausbalanciertes Velo

Die optimale Balance ist die fundamentale Philosophie, auf der das Design und die Fabrikation aller Argon 18 Velos beruht. Letztendlich handelt es sich um die subtile Alchemie zwischen Leichtbau, Steifigkeit, Komfort und Aerodynamik.

Das Resultat? Ein Velo, das eine hohe Performance liefert, das einfach zu fahren ist, wendig in den Steigungen und flink in den Abfahrten - dies alles bewirkt ein hohes Mass an Zufriedenheit, welche unnötige Müdigkeit verhindert.

Viel mehr als eine simple Idee, die optimale Balance ist die Frucht von über 25 Jahren vertiefter Studien, Forschung und Entwicklung durch unser Team; welche Argon 18's Ruf als weltweit führender Hersteller von High-End Velos bestätigt.

Erleben Sie den Unterschied von Argon 18.

Un vélo parfaitement équilibré

Le parfait équilibre est une véritable philosophie. C'est sur cette philosophie que reposent la conception et la fabrication de tous les vélos Argon 18. Ce parfait équilibre n'est autre que la subtile alchimie entre légèreté, rigidité, confort et aérodynamisme.

Le résultat ? Un vélo affichant de solides performances, facile à conduire, maniable dans les montées et vif au démarrage. En d'autres termes, un vélo qui fait tout sauf vous fatiguer inutilement.

Bien plus qu'une simple idée, le parfait équilibre est le fruit de plus de 25 années d'études, de recherche et développement menés par nos équipes. C'est cette expertise qui permet aujourd'hui à Argon 18 d'être le leader mondial de la fabrication de vélos haut de gamme.

Avec Argon 18, vivez une expérience unique.



LIGHTWEIGHT • OPTIMAL BALANCE • RIGIDITY • COMFORT

18

GALLIUM PRO

NEW

// Rahmen // cadre

Carbon, ca. 790g
XXS, XS, S, M, L, XL

// Cockpit

3T Pro	+0.-
3T Team/LTD Stealth (Carbon)	+375.-
Lenker/guidon: 3T Superergo Pro (3T Pro)	+25.-
Lenker/guidon: 3T Aeronova Team Stealth (3T Pro)	+125.-

// Kurbel // pédalier

Sram Red Quard Powermeter (only Sram)	+650.-
Shimano Powermeter Dura Ace	+875.-
Ultegra	+1175.-

// Laufräder // roues

DT Swiss PR 1400 Dicut 21 OXIC	+0.-
Fulcrum Racing Zero	+100.-
Fulcrum Racing Zero NITE	+375.-
Zipp 302 Carbon	+500.-

// Bereifung // pneu

Michelin Pro V2 black 23mm / 25mm	+0.-
Schwalbe One-V-Guard black 23mm / 25mm	+0.-
Continental Grand Prix 4000S II 23mm / 25mm	+0.-

// Sattel // selle

Selle Italia SLR Ti	+0.-
Selle Italia Lady Flow	+0.-
Selle Italia SLR Flow	+0.-
fi'zi:k Arione Wing Flex	+0.-
fi'zi:k Arione Donna Wing Flex	+0.-
fi'zi:k Antares R3	+50.-



SHIMANO DURA ACE

7595.- Di2

6295.-

SHIMANO ULTEGRA

5995.- Di2

5195.-

SRAM RED

7295.- eTap

6195.-



astana pro team (only XL-L, limited)



GALLIUM

NEW

// Cockpit

3T Pro	+0.-
Lenker/guidon: 3T Superergo Pro	+25.-

// Laufräder // roues

DT Swiss PR 1600 Spline 23	+0.-
Fulcrum Racing 3	+75.-
Ritchey WCS Zeta	+225.-
DT Swiss PR 1400 Dicut 21 OXIC	+475.-

// Bereifung // pneu

Michelin Pro 4 black 23mm / 25mm	+0.-
Schwalbe One-V-Guard black 23mm / 25mm	+0.-
Continental Grand Prix 4000S II 23mm / 25mm	+0.-

// Rahmen // cadre

Carbon, ca. 965g
XXS, XS, S, M, L, XL

// Sattel // selle

Selle Italia SLS Flow	+0.-
Selle Italia Lady Flow	+0.-
fi'zi:k Arione Donna Wing Flex	+0.-
fi'zi:k Arione Wing Flex	+25.-
Selle Italia SLR Ti	+25.-



SHIMANO ULTEGRA
4595.- Di2
3895.-

SHIMANO 105
3595.-

SRAM FORCE 22
3895.-



NITROGEN PRO

// Rahmen // cadre
Carbon, ca. 833 g
XS, S, M, L, XL

// Cockpit

Argon18 Nitrogen Pro Carbon +0.-

// Kurbel // pédalier

Sram Red Quard Powermeter (only Sram) +650.-
Shimano Powermeter Dura Ace +875.-
Ultegra +1175.-

// Laufräder // roues

DT Swiss PR 1600 Spline 32 +0.-
Fulcrum Racing 3 +75.-
Ritchey WCS Zeta +225.-
Fulcrum Racing Quattro Carbon +900.-

// Bereifung // pneu

Michelin Pro 4 black 23mm +0.-
Schwalbe One-V-Guard black 23mm +0.-
Continental Grand Prix 4000S II 23mm +0.-

// Sattel // selle

Selle Italia SLR Ti +0.-
Selle Italia Lady Flow +0.-
Selle Italia SLR Flow +0.-
fi'zi:k Arione Wing Flex +0.-
fi'zi:k Arione Donna Wing Flex +0.-
fi'zi:k Arione R3 +50.-



SHIMANO DURA ACE
8195.- Di2
6895.-

SHIMANO ULTEGRA
6495.- Di2
5695.-

SRAM RED
7795.- eTap
6695.-



NITROGEN

// Rahmen // cadre
Carbon, ca. 990g
XS, S, M, L, XL

// Cockpit

3T Pro	+0.-
Lenker/guidon: 3T Superergo Pro	+25.-

// Laufräder // roues

Fulcrum Racing Quattro LG	+0.-
DT Swiss PR 1600 Spline 32	+75.-
Fulcrum Racing 3	+150.-
Ritchey WCS Zeta	+300.-

// Bereifung // pneu

Michelin Pro 4 black 23mm	+0.-
Schwalbe One-V-Guard black 23mm	+0.-
Continental Grand Prix 4000S II 23mm	+0.-

// Sattel // selle

Selle Italia SLS Flow	+0.-
Selle Italia Lady Flow	+0.-
fi'zi:k Arione Donna Wing Flex	+0.-
fi'zi:k Arione Wing Flex	+25.-
Selle Italia SLR Ti	+25.-



SHIMANO ULTEGRA
4895.- Di2
4095.-

SHIMANO 105
3795.-

SRAM FORCE 22
4095.-



KRYPTON

// Rahmen // cadre
Carbon, ca. 1190 g
XS, S, M, L, XL

// Cockpit

Ritchey HP black +0.-

// Laufräder // roues

Fulcrum Racing 7 LG +0.-

Fulcrum Racing Quattro LG +150.-

Fulcrum Racing 3 +300.-

Ritchey WCS Zeta +450.-

// Bereifung // pneu

Michelin Lithion 2 black 23mm/ 25mm +0.-

Continental Grand Prix 4000S II black 23mm/ 25mm +50.-

// Sattel // selle

Selle Italia SLS Flow +0.-

Selle Italia Lady Flow +0.-

fi'zi:k Arione Donna Wing Flex +0.-

fi'zi:k Arione Wing Flex +25.-

Selle Italia SLR Ti +25.-



SHIMANO ULTEGRA
3595.- Di2
2795.-

SHIMANO 105
2495.-

SRAM FORCE 22
2795.-



GO!

NEW

// Cockpit

Ritchey Comp BB black +0.-

// Laufräder // roues

Fulcrum Racing 7 +0.-

DT Swiss P1800 Spline 23 +75.-

Fulcrum Racing Quattro LG +150.-

DT Swiss PR 1600 Spline 23 +225.-

// Bereifung // pneu

Michelin Lithion 2 black 23mm/ 25mm +0.-

Continental Grandd Prix 4000S II black 23mm/ 25mm +50.-

// Sattel // selle

Selle Italia SLS Flow +0.-

Selle Italia Lady Flow +0.-

fi'zi:k Arione Wing Flex +25.-

// Rahmen // cadre

Carbon, ca. 1180g
XXS, XS, S, M, L, XL



SHIMANO ULTEGRA	SHIMANO 105
3295.- Di2	2195.-
2495.-	



black / electric mint



GALLIUM PRO DISC

NEW

// Rahmen // cadre
Carbon, ca. 790g
XXS, XS, S, M, L, XL

// Cockpit

3T Pro	+0.-
3T Team/LTD Stealth (carbon)	+375.-
Lenker/guidon: 3T Superergo Pro (3T Pro)	+25.-
Lenker/guidon: 3T Aeronova Team Stealth (3T Pro)	+125.-

// Kurbel // pédalier

Sram Red Quard Powermeter (only Sram)	+650.-
Shimano Powermeter Dura Ace	+875.-
Ultegra	+1175.-

// Laufräder // roues

Fulcrum Racing 400 Disc	+0.-
DT Swiss PR 1600 Spline 23 Disc	+75.-
DT Swiss PR 1400 Dicut 21	+400.-
Zipp 302 Carbon Disc	+1050.-

// Bereifung // pneu

Continental Grand Prix 4000S II black 25mm	+0.-
Michelin Pro Endurance V2 black 25mm	+0.-

// Sattel // selle

Selle Italia SLR Ti	+0.-
Selle Italia Lady Flow	+0.-
Selle Italia SLR Flow	+0.-
fi'zi:k Arione Wing Flex	+0.-
fi'zi:k Arione Donna Wing Flex	+0.-
fi'zi:k Antares R3	+50.-



SHIMANO DURA ACE	SHIMANO ULTEGRA	SRAM RED
7495.- Di2	5895.- Di2	7295.- eTap
6195.-	5095.-	6295.-



KRYPTON XROAD

// Rahmen // cadre
Carbon, ca. 1190 g
XS, S, M, L, XL

// Cockpit

Ritchey HP black +0.-

// Laufräder // roues

DT Swiss P1800 Spline 23 Disc +0.-
Fulcrum Racing 500 Disc +50.-
Fulcrum Racing 400 Disc +100.-
DT Swiss PR 1600 Spline 32 Disc +175.-

// Bereifung // pneu

Michelin Lithion 2 black 25mm +0.-
Continental Grand Prix 4000S II black 25mm +50.-

// Sattel // selle

Selle Italia SLS Flow +0.-
Selle Italia Lady Flow +0.-
fi'zi:k Arione Donna Wing Flex +0.-
fi'zi:k Arione Wing Flex +25.-
Selle Italia SLR Ti +25.-

SHIMANO ULTEGRA
4195.- Di2
3295.-

SHIMANO 105
2995.-

SRAM FORCE 22
3495.-



E-119 TRI+

// Cockpit

Argon 18 E-119 Carbon +0.-

// Kurbel // pédalier

Sram Red Quard Powermeter (only Sram) +650.-

Shimano Powermeter Dura Ace +875.-

Ultegra +1175.-

Rotor IN-Power 3D+ Dura Ace +475.-

Ultegra +800.-

Sram +525.-

Kettenblätter/plateaux: Classic Q-Rings +50.-

// Laufräder // roues

Fulcrum Red Wind H.50 +0.-

Fulcrum Racing Quattro Carbon +150.-

Zipp 404 Firecrest Carbon Clincher +1000.-

Zipp 404/808 Firecrest Carbon Clincher +1150.-

// Bereifung // pneu

Michelin Pro 4 black 23mm / 25mm +0.-

Schwalbe One-V-Guard black 23mm / 25mm +0.-

Continental Grand Prix 4000S II black 23mm / 25mm +0.-

// Sattel // selle

fi'zi:k Mistica Regular +0.-

Astute Sealite VT Carbon +75.-

// Rahmen // cadre

Carbon, ca. 1200g
XS, S, M, L



SHIMANO DURA ACE

9495.- Di2

7895.-

SHIMANO ULTEGRA

8195.- Di2

6995.-

SRAM RED

9095.- eTap

8495.-

// Nur als Kit erhältlich, die Kosten für Montage und Fitting durch den autorisierten Argon18 Fachhändler sind nicht inbegriffen.



E-119 TRI

// Rahmen // cadre
Carbon, ca. 1310g
XS, S, M, L

// Cockpit

Argon 18 E-119 Carbon +0.-

// Kurbel // pédalier

Sram Red Quard Powermeter	+650.-
Shimano Powermeter Dura Ace	+875.-
Ultegra	+1175.-
Rotor IN-Power 3D+ Dura Ace	+475.-
Ultegra	+800.-
Sram	+525.-
Kettenblätter/plateaux: Classic Q-Rings	+50.-

// Laufräder // roues

Fulcrum Red Wind H.50	+0.-
Fulcrum Racing Quattro Carbon	+150.-
Zipp 404 Firecrest Carbon Clincher	+1000.-
Zipp 404/808 Firecrest Carbon Clincher	+1150.-

// Bereifung // pneu

Michelin Pro 4 black 23mm / 25mm	+0.-
Schwalbe One-V-Guard black 23mm / 25mm	+0.-
Continental Grand Prix 4000S II black 23mm / 25mm	+0.-

// Sattel // selle

fi'zi:k Mistica Regular	+0.-
Astute Sealite VT Carbon	+75.-



SHIMANO DURA ACE	SHIMANO ULTEGRA	SRAM RED
8795.- Di2	7495.- Di2	8495.- eTap
7195.-	6395.-	7795.-

// Nur als Kit erhältlich, die Kosten für Montage und Fitting durch den autorisierten Argon18 Fachhändler sind nicht inbegriffen.



E-117 TRI

// Cockpit

3T Pro +0.-

// Laufräder // roues

Fulcrum Racing Quattro LG +0.-

DT Swiss PR 1600 Spline 32 +75.-

Fulcrum Red Wind H.50 +825.-

Zipp 302 Carbon +1075.-

// Bereifung // pneu

Michelin Lithion 2 black 23mm / 25 mm +0.-

Continental Grand Prix 4000S II black 23mm / 25 mm +50.-

// Sattel // selle

fi'zi:k Mistica Regular +0.-

Astute Sealite VT +75.-

// Rahmen // cadre

Carbon, ca. 1470 g

XS, S, M, L



SHIMANO ULTEGRA

4695.- Di2

3595.-

SHIMANO 105

3395.-

// Nur als Kit erhältlich, die Kosten für Montage und Fitting durch den autorisierten Argon18 Fachhändler sind nicht inbegriffen.



Geometry

	A	B	C	D	H1	H2	H3
GALLIUM PRO							
XXS	420	75,5°	71,0°	499	75	90	100
XS	455	74,5°	72,0°	519	85	100	110
S	493	74,0°	72,7°	539	110	125	135
M	530	73,5°	72,7°	559	140	155	165
L	565	73,0°	72,7°	577	165	180	190
XL	595	72,5°	73,0°	596	185	200	210

	A	B	C	D	H1	H2	H3
GALLIUM							
XXS	415	75,5°	71,0°	502	77	91	101
XS	455	74,5°	72,0°	520	82	96	106
S	490	74,0°	72,7°	540	109	123	133
M	530	73,5°	72,7°	560	139	153	163
L	565	73,0°	72,7°	575	162	176	186
XL	595	72,5°	73,0°	595	189	203	213

	A	B	C	D	H1	H2	H3
NITROGEN PRO / NITROGEN							
XS	433	74,5°	72,0°	520	81	96	106
S	487	74,0°	72,7°	537	109	124	134
M	515	73,5°	72,7°	556	141	156	166
L	567	73,0°	72,7°	575	162	177	187
XL	596	72,5°	73,0°	595	188	203	213

	A	B	C	D	H1	H2	H3
KRYPTON							
XS	465	74,5°	72,0°	520	100	114	124
S	513	74,0°	72,7°	540	123	137	147
M	550	73,5°	72,7°	556	147	161	171
L	575	73,0°	72,7°	575	173	187	197
XL	600	72,5°	73,0°	595	195	209	219

	A	B	C	D	H1	H2	H3
GO!							
XXS	420	75,5°	70,3°	500	95	-	120
XS	455	74,5°	71,4°	520	105	-	130
S	500	74,0°	72,0°	535	129	-	154
M	540	73,5°	72,0°	556	151	-	176
L	561	73,0°	72,0°	575	181	-	206
XL	595	72,5°	73,0°	595	210	-	235

	A	B	C	D	H1	H2	H3
GALLIUM PRO DISC							
XXS	420	75,5°	71,0°	499	75	90	100
XS	455	74,5°	72,0°	519	85	100	110
S	493	74,0°	72,7°	539	110	125	135
M	530	73,5°	72,7°	559	140	155	165
L	565	73,0°	72,7°	577	165	180	190
XL	595	72,5°	73,0°	596	185	200	210

	A	B	C	D	H1	H2	H3
KRYPTON XROAD							
XS	455	74,5°	71,4°	520	107	121	131
S	500	74,0°	72,0°	535	130	144	154
M	540	73,5°	72,0°	550	152	166	176
L	560	73,0°	72,0°	570	183	197	207
XL	595	72,5°	72,3°	590	212	226	236

	A	B	C	D	H1
E-119 TRI+ / E-119 TRI					
XS	455	78,0°	72,0°	491	60
S	502	78,0°	72,0°	503	70
M	516	78,0°	72,0°	517	86
L	542	78,0°	72,0°	527	112

	A	B	C	D	H1
E-117 TRI					
XS	461	78,0°	72,0°	489	84
S	500	78,0°	72,0°	501	95
M	515	78,0°	72,0°	514	111
L	547	78,0°	72,0°	525	139

- A** Grösse / Taille
- B** Sitzwinkel / Inclinaison selle
- C** Steuerwinkel / Inclinaison direction
- D** Oberrohrlänge / Longueur tube supérieur
- H** Steuerrohrlänge / Longueur tube de direction

Alle Höhen Mitte Tretlager bis Ende Sitzrohr gemessen, alle Längenangaben in Millimeter, alle Winkel in Grad, alles unverbindliche Angaben.

Hauteurs mesurées du milieu du pédalier jusqu'à l'extrémité du tube de selle, longueurs en millimètres, inclinaisons en degrés, toutes les données sont sans engagement.

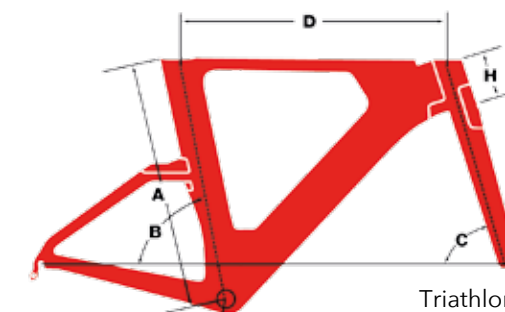
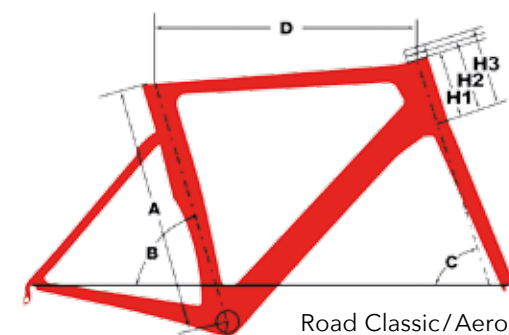

Parts

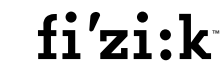

ROAD



FULCRUM RACING ZERO NITE
1506g



FULCRUM RACING ZERO
1518g



FULCRUM RACING 3
1560g



FULCRUM RACING QUATTRO CARBON
1555g



FULCRUM RACING QUATTRO LG
1720g



FULCRUM RACING 7 LG
1763g



FULCRUM RED WIND H.50
1755g



DT SWISS PR 1400
1417g



DT SWISS PR 1600
1591g



DT SWISS P 1800
1596g



RITCHEY WCS ZETA
1444g



ZIPP 302 CARBON
1604g



ZIPP 404 FIRECREST CARBON
1690g



ZIPP 808 FIRECREST CARBON
1700g

ROAD DISC



FULCRUM RACING 4 DISC
1690g



FULCRUM RACING 5 DISC
1610g



DT SWISS PR 1400 DISC
1443g



DT SWISS PR 1600 DISC
1658g



DT SWISS P 1800 DISC
1675g



ZIPP 302 CARBON DISC
1695g

SADDLES



FI'ZI:K ARIONE WING FLEX
225g



FI'ZI:K ARIONE DONNA WING FLEX
240g



FI'ZI:K ANTARES R3
165g



FI'ZI:K MISTICA REGULAR
235g



ASTUTE SEALITE VT
185g



SELLE ITALIA SLR TI
175g



SELLE ITALIA SLR FLOW
190g



SELLE ITALIA SLS FLOW
225g



SELLE ITALIA LADY FLOW
270g



ARGON 18

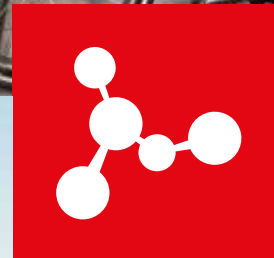

WWW.ARGON18-BIKE.CH

design skyPixX